

NOTES:
 1. VERIFY ALL DIMENSIONS AND LOCATIONS WITH SURVEYOR.
 2. VERIFY ALL DIMENSIONS AND LOCATIONS WITH SURVEYOR.
 3. VERIFY ALL DIMENSIONS AND LOCATIONS WITH SURVEYOR.
 4. VERIFY ALL DIMENSIONS AND LOCATIONS WITH SURVEYOR.
 5. VERIFY ALL DIMENSIONS AND LOCATIONS WITH SURVEYOR.
 6. VERIFY ALL DIMENSIONS AND LOCATIONS WITH SURVEYOR.
 7. VERIFY ALL DIMENSIONS AND LOCATIONS WITH SURVEYOR.
 8. VERIFY ALL DIMENSIONS AND LOCATIONS WITH SURVEYOR.
 9. VERIFY ALL DIMENSIONS AND LOCATIONS WITH SURVEYOR.
 10. VERIFY ALL DIMENSIONS AND LOCATIONS WITH SURVEYOR.
 11. VERIFY ALL DIMENSIONS AND LOCATIONS WITH SURVEYOR.
 12. VERIFY ALL DIMENSIONS AND LOCATIONS WITH SURVEYOR.
 13. VERIFY ALL DIMENSIONS AND LOCATIONS WITH SURVEYOR.
 14. VERIFY ALL DIMENSIONS AND LOCATIONS WITH SURVEYOR.
 15. VERIFY ALL DIMENSIONS AND LOCATIONS WITH SURVEYOR.
 16. VERIFY ALL DIMENSIONS AND LOCATIONS WITH SURVEYOR.
 17. VERIFY ALL DIMENSIONS AND LOCATIONS WITH SURVEYOR.
 18. VERIFY ALL DIMENSIONS AND LOCATIONS WITH SURVEYOR.
 19. VERIFY ALL DIMENSIONS AND LOCATIONS WITH SURVEYOR.
 20. VERIFY ALL DIMENSIONS AND LOCATIONS WITH SURVEYOR.

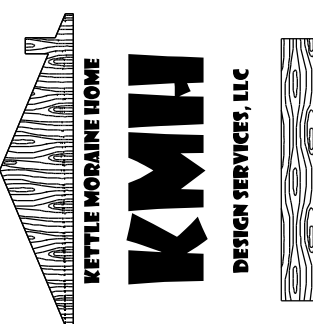

HOME DESIGNS CRAFTED FOR YOUR LIFESTYLE
 607 KETTLE HOUSING DRIVE S.
 STINGER WPT, WI 53186
 E-MAIL: KMHDESIGN@PROFESSIONAL.COM

JOHANSEN ADDITION
 5857 EAGLE POINT ROAD
 TOWN OF HARTFORD
 WASHINGTON CT. WIS.

TITLE	FOUNDATION/ LOWER LEVEL PLAN	DATE	5-18-2024
DRAWN BY	TERRY	SCALE	1/4" = 1'-0"
SHEET	A1		

FRAMING/FINISH NOTES:

- BUMP PUMP CROCK, CONFIRM LOCATION ON SITE.
- PRESSURE TANK, FIELD VERIFY LOCATION.
- TANKLESS WATER HEATER, COORDINATE UNIT SIZE AND LOCATION W/PLUMBING SUB-CONTRACTOR.
- WATER SOFTNER/BRINE TANK, VERIFY LOCATION IN FIELD.
- FLOOR DRAIN, COORDINATE LOCATION IN FIELD.
- FORCED AIR GAS FURNACE, HVAC SUB-CONTRACTOR TO COORDINATE UNIT SIZE, VERIFY LOCATION IN FIELD.
- NEO-ANGLE CORNER SHOWER MODULE.
- (2) FLY DROPPED 2 X 10 HEADER.
- COORDINATE W/ CLIENT SHOWER HEADER LOCATION.
- CLIENT TO COORDINATE INSTALLATION OF SAUNA ROOM AND ALL COMPONENTS.
- 6 X 6 TREATED POST SET ON 18" DIA. CONCRETE FILLED SONATUBE PILEASTER.

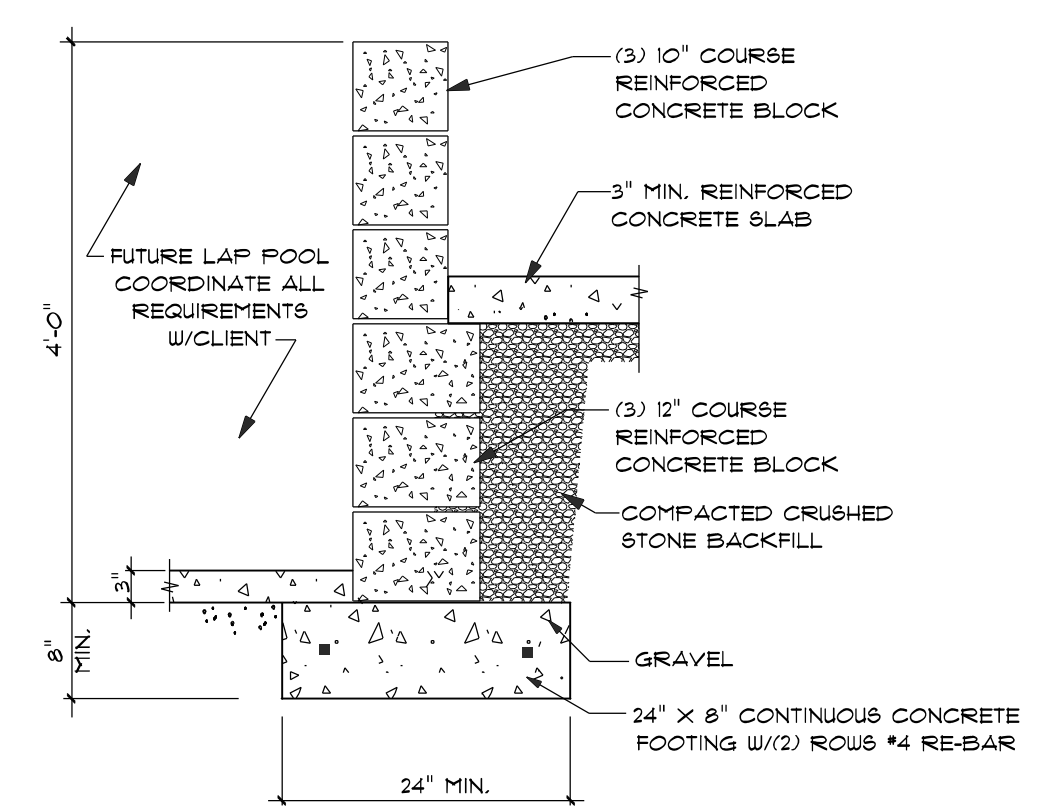
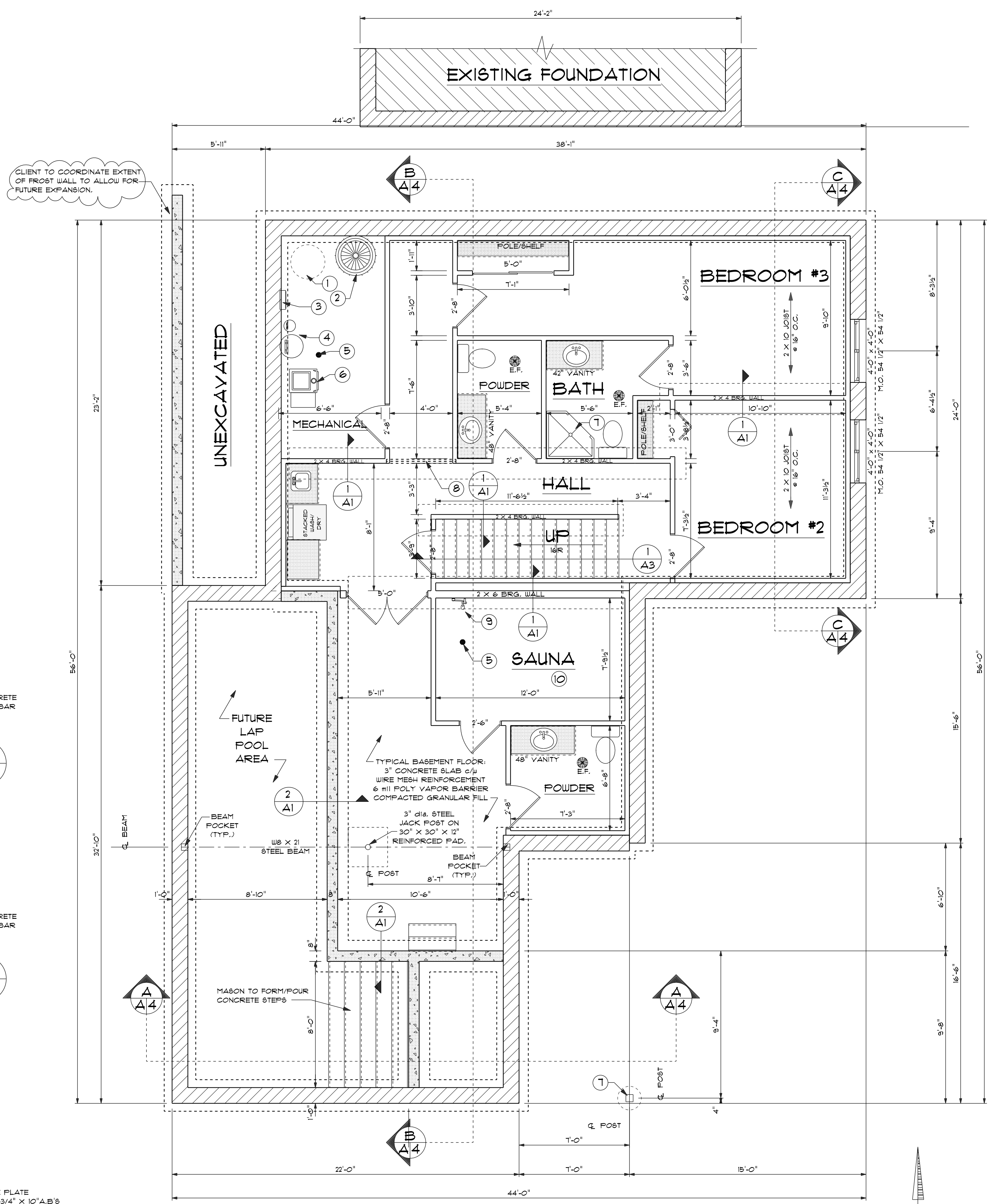

INT. BEARING WALL DETAIL 2
 NOT TO SCALE

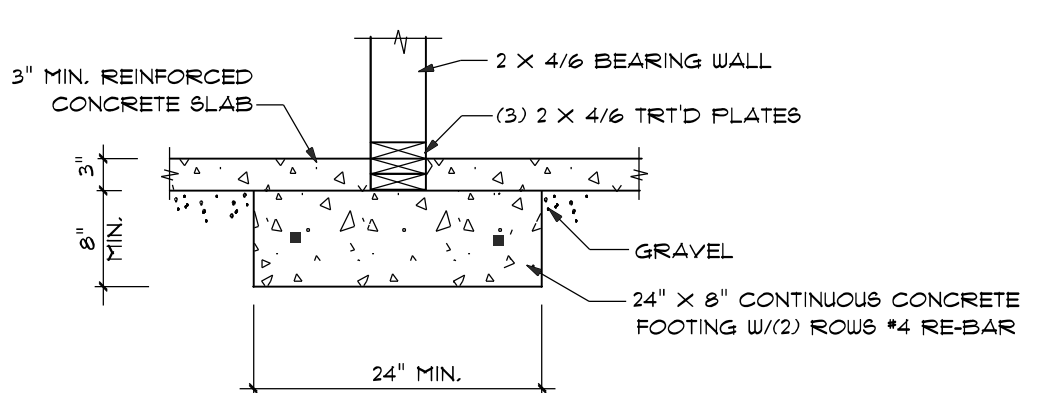

INT. BEARING WALL DETAIL 1
 NOT TO SCALE

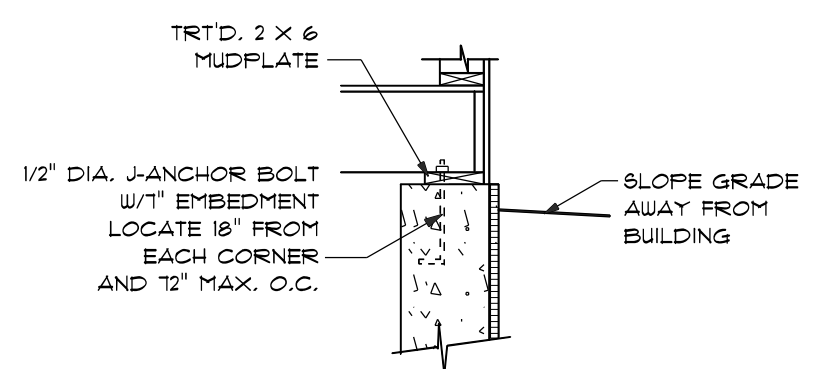

ANCHOR BOLT DETAIL

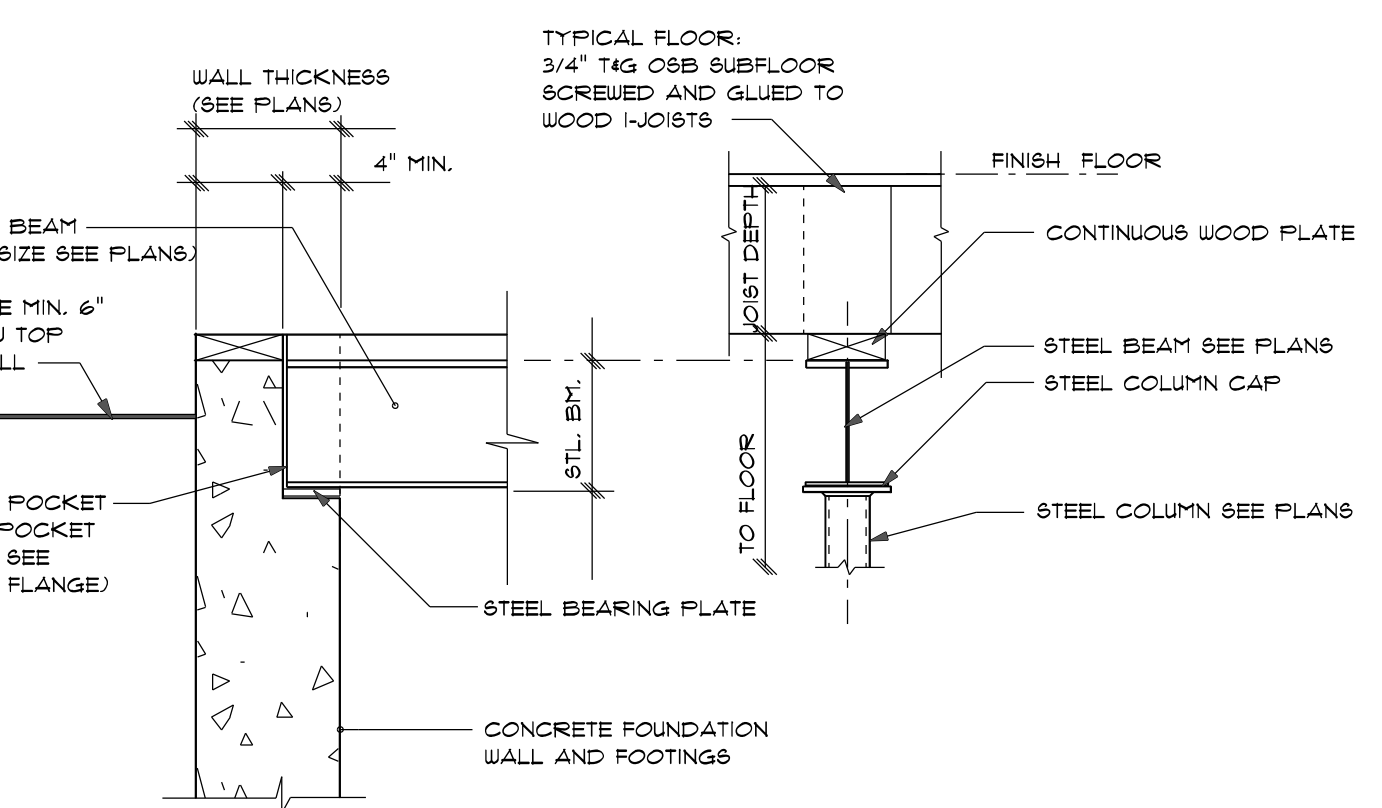

TYPICAL BEAM DETAIL STEEL / BOTTOM BEARING

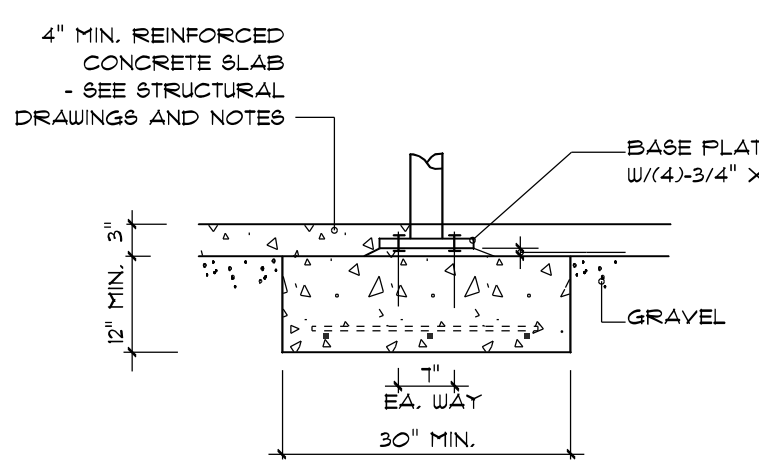

TYP. PIPE COL. ANCHORAGE DETAILS

LEGEND

- ☼ SMOKE DETECTOR
- ▲ CARBON MONOXIDE DETECTOR
- ⊙ EXHAUST FAN
- ⊥ HOSE BIBB
- Ⓐ WINDOW KEY
- Ⓛ CALLOUT KEY

NOTES

ALTHOUGH EVERY EFFORT HAS BEEN MADE IN PREPARING THIS PLAN FOR ACCURACY, THE OWNER/GENERAL CONTRACTOR MUST CHECK ALL DIMENSIONS AND VERIFY EACH DETAIL AND BE RESPONSIBLE FOR THE SAME.

EXTERIOR DIMENSIONS ARE TO FACE OF MASONRY AND/OR SHEATHING UNLESS NOTED OTHERWISE.

INTERIOR DIMENSIONS ARE TO FACE OF STUDS UNLESS NOTED OTHERWISE.

ALL WORK SHALL BE COMPLETED IN ACCORDANCE WITH THE MINIMUM REQUIREMENTS AS NOTED BY THE STATE OF WISCONSIN 'UNIFORM BUILDING CODE' EXCEPT WHERE MORE RESTRICTIVE LOCAL ORDINANCES SHALL GOVERN.

THE OWNER/GENERAL CONTRACTOR SHALL VERIFY AS REQUIRED AND COORDINATE PLACEMENT AND INSTALLATION OF ALL MECHANICAL PLUMBING AND ELECTRICAL EQUIPMENT AND UTILITY SERVICE LINES/EQUIPMENT.

FOR PLACEMENT OF BUILDING ON LOT, REFER TO SURVEYOR'S DRAWINGS. GRADE LINES SHOWN ARE FOR REFERENCE ONLY; CONFIRM FINAL GRADE LINES WITH SURVEY AND EXCAVATOR AT JOB SITE AS REQUIRED.

WINDOWS NOTED ARE GLAZED UNITS WITH LOW 'E' GLASS SEE SCHEDULE ELSEWHERE.

DO NOT SCALE DIMENSIONS FROM DRAWINGS. CONSULT WITH GENERAL CONTRACTOR AND/OR DESIGNER FOR VERIFICATION.

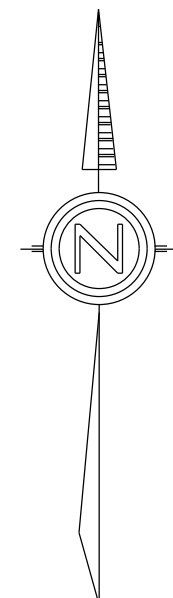

FOUNDATION/LOWER LEVEL PLAN
 SCALE: 1/4" = 1'-0"